

Document Title: Advanced Filter Evaluation and Limit Testing (AN 357-3)

Part Number: 5950-2933

Revision Date: April 1988

Silicon Investigations
Repair Information - Contact Us
920-955-3693
www.siliconinvestigations.com

HP References in this Application Note

This application note may contain references to HP or Hewlett-Packard. Please note that Hewlett-Packard's former test and measurement, semiconductor products and chemical analysis businesses are now part of Agilent Technologies. We have made no changes to this application note copy. The HP XXXX referred to in this document is now the Agilent XXXX. For example, model number HP8648A is now model number Agilent 8648A.

About this Application Note

We've added this application note to the Agilent website in an effort to help you support your product. This manual provides the best information we could find. It may be incomplete or contain dated information, and the scan quality may not be ideal. If we find a better copy in the future, we will add it to the Agilent website.

Support for Your Product

Agilent no longer sells or supports this product. You will find any other available product information on the Agilent website:

www.agilent.com

Search for the model number of this product, and the resulting product page will guide you to any available information. Our service centers may be able to perform calibration if no repair parts are needed, but no other support from Agilent is available.



Advanced Filter Evaluation and Limit Testing

with

HP 4195A Network/Spectrum Analyzer

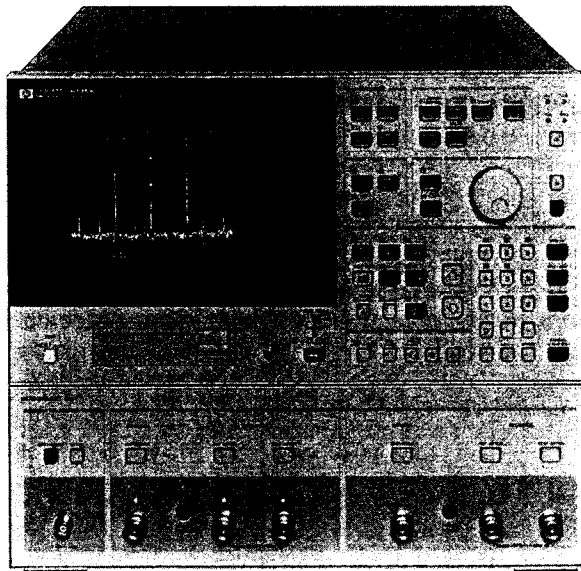

1. INTRODUCTION

Filters play a significant roll in electronic equipment because of the decisive effect they have on the performance of the equipment in which they are used. Filters find extensive use in communication, telecommunication, and consumer electronics. These products are becoming more complicated and require higher quality signal processing. For example, the amount of information sent by telecommunication networks has increased (requiring more stringent performance from the filters used in these systems), and VCR's/TV's require higher quality signal for better picture resolution and quality (sharper vision). As the demand for higher quality and more sophisticated electronic equipment increases, so has the need for accurate high speed testing and characterization of the wide variety of filters used.

Both end users and filter manufactures need to be able to quickly and easily test a wide variety of filters to ever increasingly tighter tolerances. This application note describes how the HP 4195A Network/Spectrum Analyzer is used to test filters, by either measuring the filter's parameters or by using limit lines to perform GO/NO-GO testing. Both of these test techniques can be performed without a computer by using the HP 4195A's **USER PROGRAM** programming function, a BASIC-like language used to control the HP 4195A's operation. An external computer can also be used to develop and down load **USER PROGRAMS** to the HP 4195A over the HP-IB bus and to control the operation of the HP 4195A.

2. FILTER PARAMETER MEASUREMENT

When testing filters, several of the filter's parameters are derived from the filter's measured transmission characteristics. Older network analyzers required using markers or other functions which required several key stroke operations and special operator skill to obtain valid results. The HP 4195A's **USER DEFINE** function gives the user the power of assigning complicated, hard to remember, error prone multiple key and softkey key strokes operations to a single key (keyboard macros), so filter parameters can now be measured and displayed using a single key stroke operation. The **USER DEFINE** function gives the user the power to define a single key stroke function to replace multiple key and softkey operations. As an example, this section shows how to use the **USER DEFINE** keys to find the following parameters:

- 1) -3 dB Band Width
- 2) Insertion Loss
- 3) Center Frequency
- 4) Band Pass Filter Rejection Characteristics

Figure 1 shows the filter test configuration used. A power splitter is required for this measurement. The **USER DEFINE** keys are defined using a **USER PROGRAM**. The program listing for Program 1 is given in the Appendix of this application note. After executing this program, press the 'USER DEFINE' key. Softkeys defined by a **USER PROGRAM** will be displayed as shown in Figure 2. When the 'USER DEFINED' key is pressed, each parameter is displayed at the bottom of the screen as shown in Figure 3. When using this technique, a filter's parameters are easily obtained with just a single key stroke, no time consuming, error prone key stroke sequences or function/measurement sequences need be performed.

The HP 4195A can output measurement parameters directly to an HP-IB printer. Figure 3 shows a sample print out of measurement parameters obtained using this technique, the program listing is given in Program 2 in the Appendix of this application note.

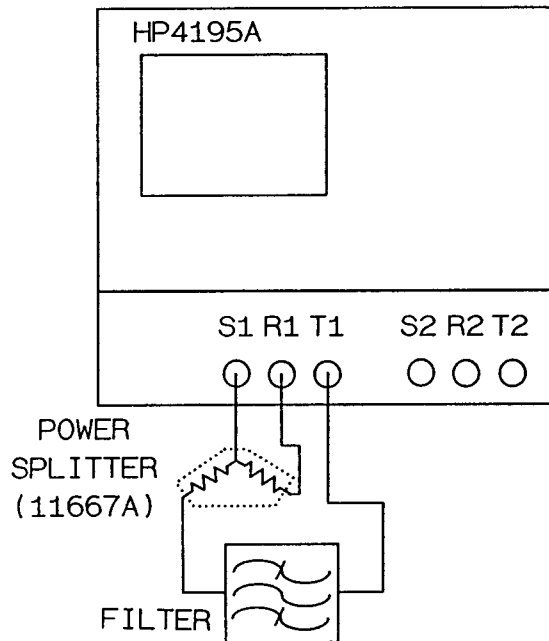
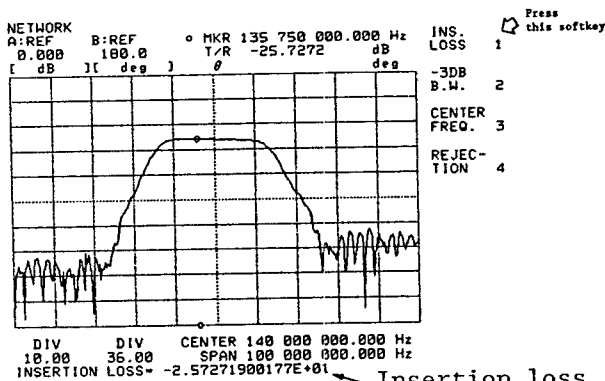
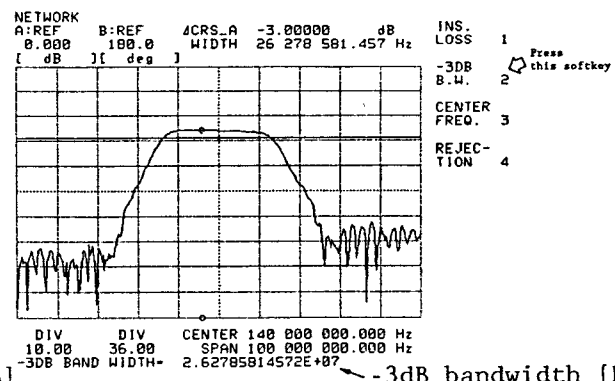

Figure 1. Filter Testing Configuration



Insertion loss [dB] is displayed here

(a) Insertion Loss



-3dB bandwidth [Hz] is displayed here

(b) -3dB Bandwidth

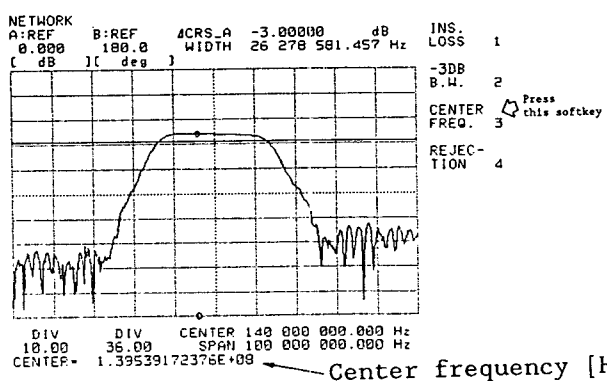

Center frequency [Hz] is displayed here

(c) Center Frequency

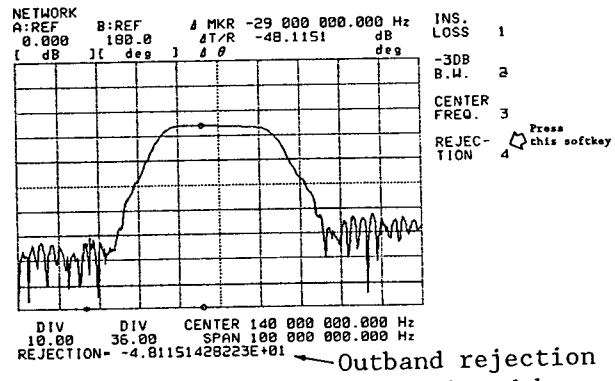

Outband rejection [dB] is displayed here

(d) Rejection

Figure 2. Filter Parameters

```

INSERTION LOSS [DB]
-2.55817832947E+01

-3DB BAND WIDTH [HZ]
2.63951934003E+07

CENTER FREQUENCY [HZ]
1.39858385351E+08

REJECTION [DB]
-4.68137321472E+01

```

Figure 3. Example of Parameter Printout

3. GO/NO-GO TESTING

The HP 4195A can be used to perform GO/NO-GO testing using limit lines. Before running the GO/NO-GO program listed in Program 4, the limit lines setup program, Program 3, must be executed.

3-1. Limit Line Setting

Limit lines are composed of a series of straight line segments as shown in Figure 4. Each segment is specified by its start and stop coordinates. These coordinates are given as frequency and power level (f,p) or (f',p') for the minimum and maximum limit points. Various shapes of limit lines can be created by modifying the setup program. The frequencies and power levels can be modified by changing lines 300-560 of Program 3, and the number of segment points can be modified in line 270. The following procedure generates and stores the limit lines.

- 1) Before executing Program 3, modify the frequencies and power levels for each segment and set the instrument settings as required.
- 2) Connect the DUT as shown in Figure 1.
- 3) Execute Program 3, the HP 4195A will display the limit lines and the measurement data of the DUT as shown in Figure 5.
- 4) If you want to modify the limit lines, press the **USER DEFINE** key, then move a marker to a point you want to modify and press the softkeys to modify the limit lines displayed on the screen, as shown in Figure 6.
- 5) After setting the limit lines, the limit line data and instrument state (measurement conditions) information must be stored to a file on a floppy disc. Press the '**SAVE/GET**' key and the '**SAVE**' softkey. Choose and enter a file name, and press the '**EXEC/ENTER**' key. The data is saved on the disc and is used for the following GO/NO-GO test procedure.

f_m ; m th frequency of a maximum limit line	
p_m ; m th power level of a maximum limit line	
f'_m ; m th frequency of a minimum limit line	Each value should be
p'_m ; m th power level of a minimum limit line	modified in line 270-
n ; number of segment points	560 of Program 3.

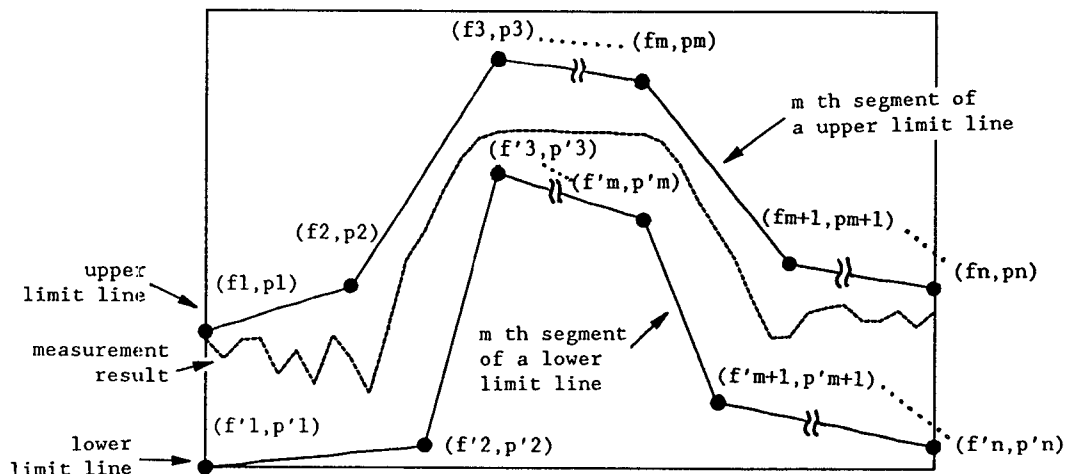

Figure 4. Segments for Limit Line

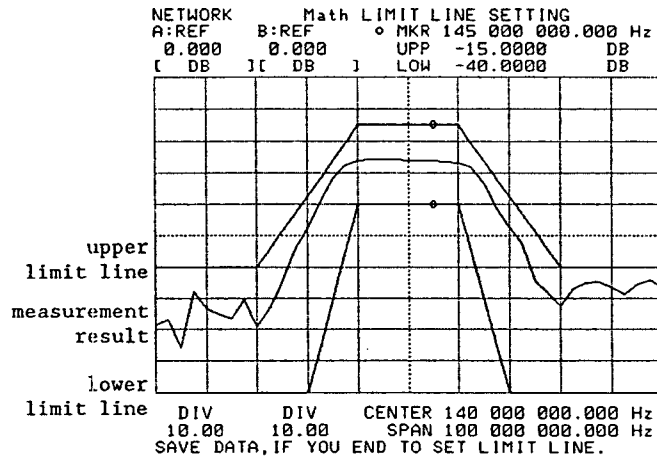

Figure 5. Limit Lines

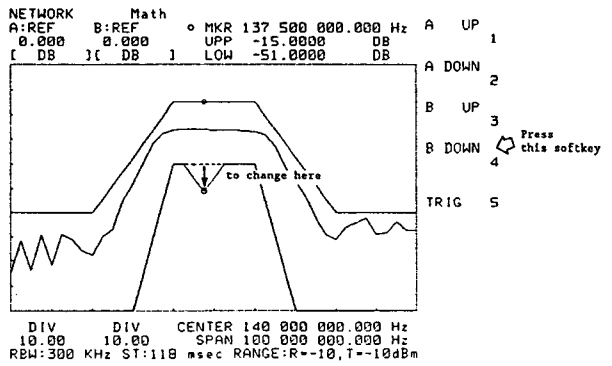
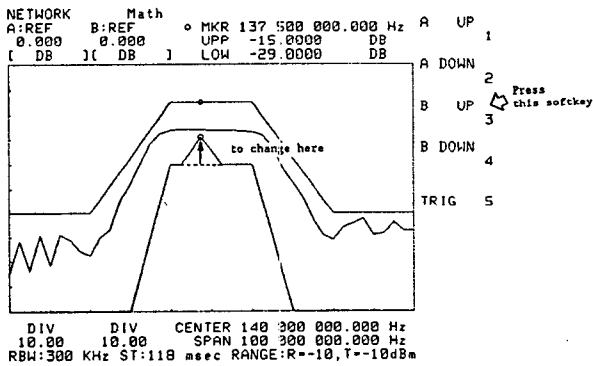
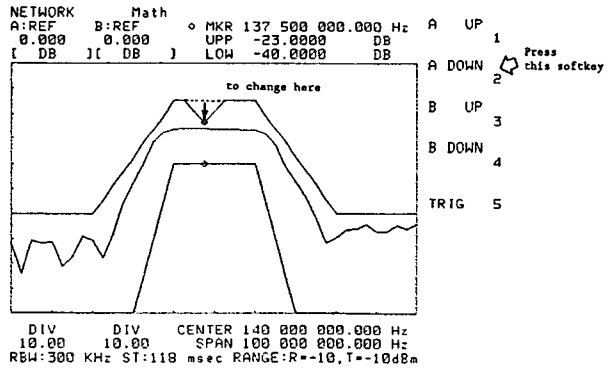
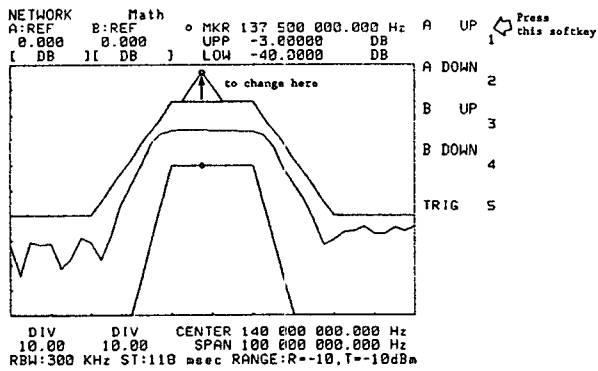

Figure 6. Limit Line Modification

3-2. GO/NO-GO Testing

After executing Program 3 to set the limit lines, the HP 4195A is ready to perform GO/NO-GO filter testing. Connect a DUT as shown in Figure 1 and execute Program 4. The GO/NO-GO test procedure is as follows:

- 1) When the program is executed, the program displays the catalog of files on the disc and then pauses.
- 2) Recall the stored limit line and instrument state data. Press the 'GET' softkey and select the data file that you stored the data in and press the 'EXEC/ENTER' key.
- 3) Press the 'PROGRAM' key and the 'CONT' softkey, the HP 4195A will start the GO/NO-GO test. Figure 7 shows some sample results of a GO/NO-GO test of a bandpass filter.
- 4) Change the DUT and press the 'CONT' key to continue the GO/NO-GO testing.

The HP 4195A's **USER FUNCTION** can be used to easily set the limit lines for filter testing. Using the HP 4195A's built-in floppy disc drive, the limit line data and instrument states are stored for recall as required anytime. GO/NO-GO testing of a variety of devices can be accomplished easily and quickly using the HP 4195A!

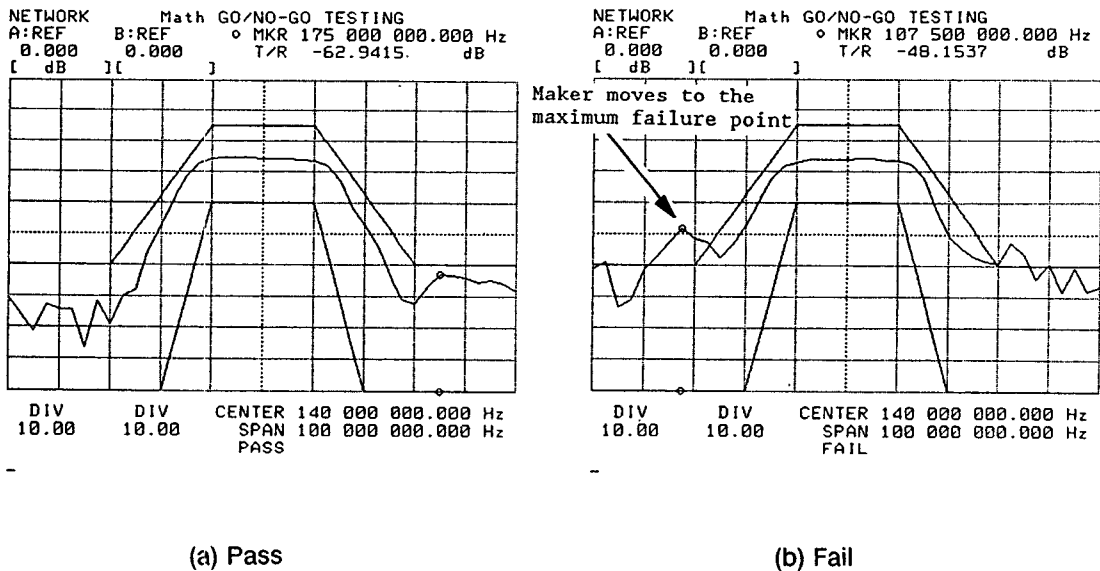

Figure 7. Results of GO/NO-GO testing

4. Advanced Filter Tests

The HP 4195A, with its many outstanding features, can be used to perform advanced test procedures on filters.

4-1. Multi-Device Measurement and Multi-Output Filter Measurement

The HP 4195A can be used to increase your measurement speed by being used with a handler to compare a test device with a standard device. Because the HP 4195A has two output channel ports and four input ports, three devices can be connected simultaneously to the HP 4195A for testing. Figure 8 shows the configuration for testing multiple devices.

The HP 4195A with its multi-inputs can measure multi-output filters such as state variable filters. Figure 9 shows a configuration for testing multi-output filters.

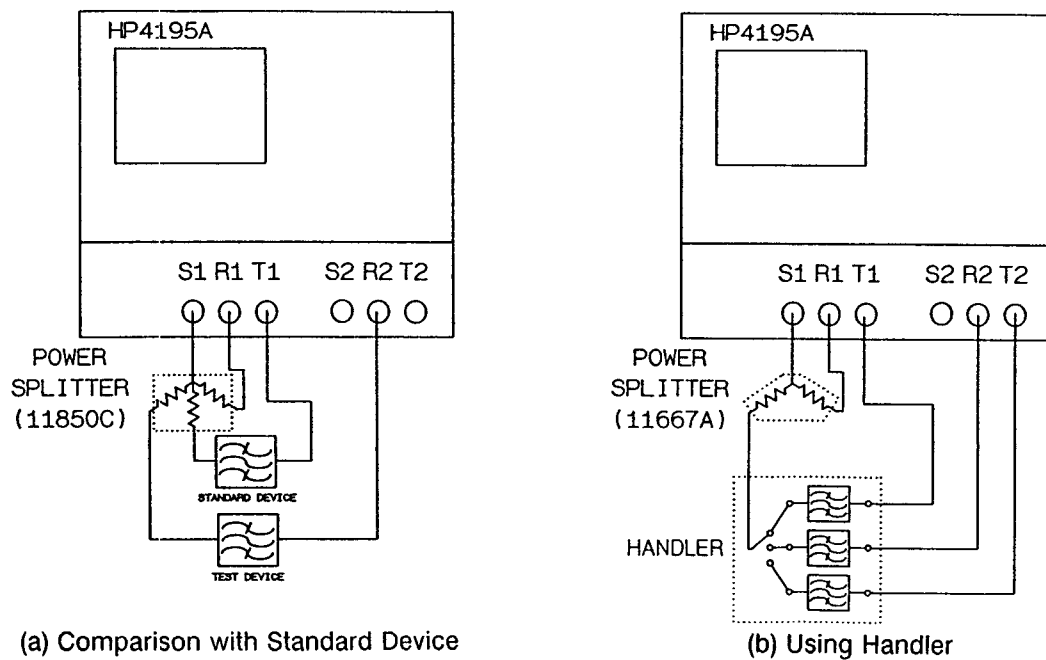

Figure 8. Example of Configuration for Multi-device Measurement

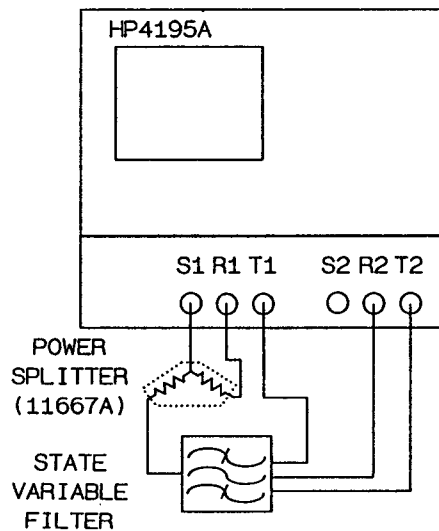

Figure 9. Example of Configuration for a State Variable Filter Testing

4-2. Phase Measurement

For filter test, in addition to measuring transmission characteristics, phase characteristics must also be measured. For example, Group Delay (derivative of phase with respect to frequency) represents phase nonlinearity, and phase nonlinearity degrades the quality of the signal.

The HP 4195A with its high accuracy and resolution can perform precise Group Delay measurements. Figure 10 shows some sample results of Group Delay measurements. The HP 4195A can simultaneously measure Group Delay and Transmission characteristics.

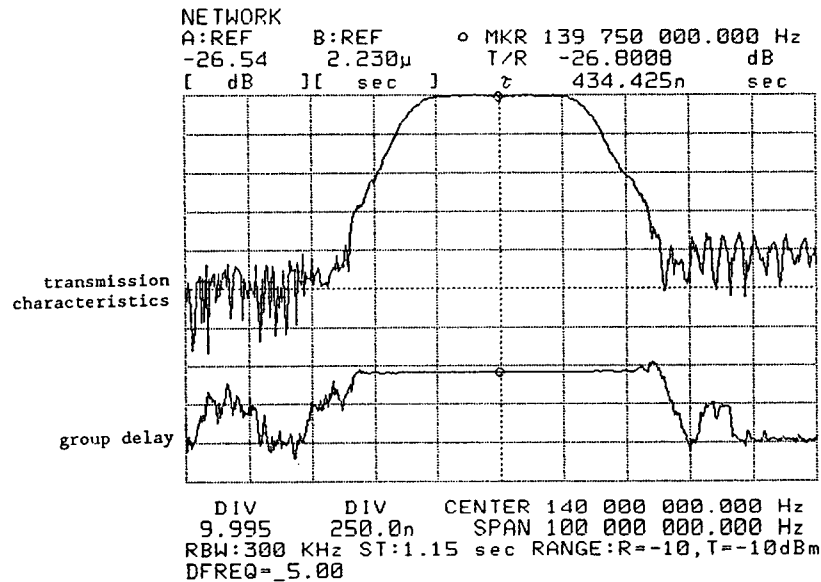

Figure 10. Group Delay and Transmission Characteristic

5. Conclusion

The HP 4195A, with its ability to provide precision transmission and phase measurement, is a very powerful tool for testing filters. The HP 4195A's **USER FUNCTION** provides for flexible, easy operation, so it can quickly and easily perform parameter measurement and GO/NO-GO testing. The flexible operation of the HP 4195A allow it to be quickly reconfigured to meet the test requirements of various test devices.

Program 1. USER DEFINE key Definition

```

100 | .....
110 | * FILTER TEST *
120 | * FINDING PARAMETER *
130 | * FOR HP 4195A * FEB.19.1988 *
140 | * YOKOGAWA-HEWLETT-PACKARD, LTD *
150 | .....
160 | ***** SETTING MES. CONDITION *****
170 | SWHZ | SINGLE SWEEP
180 | DPB0 | TRACE B OFF
190 | CENTER=140 MHZ | CENTER FREQ. 140 MHZ
200 | SPAN=100 MHZ | SPAN 100 MHZ
210 | OSC1=-10 DBM | S1 OSC. LEVEL -10 DBM
220 | ATR1=0 | RI ATTEN. 0 DB
230 | ATT1=0 | T1 ATTEN. 0 DB
240 | RBW=10 KHZ | RES. BW 10 KHZ
250 | ***** DEFINING USER DEFINE KEY *****
260 | DF1" MCF1;MKMX;R0=MKRA;DISP "INSERTION LOSS-",R0"
270 | DF2" MCF4;MKACT1;MKMX;WIDTH1;DLCURS=-3;R0=WIDTH;R0"
280 | DF3" MCF4;MKACT1;MKMX;WIDTH1;DLCURS=-3;R0=(LCURS+LCURS)/2;DISP "CENTER-",R0"
290 | DF4" MCF2;MKACT1;MKMX;SMKR=CENTER-SPAN/3;R0=DMKRA;DISP "REJECTION-",R0;DEL T1"
300 | DFS" SUTRG"
310 | ***** DEFINING LABEL OF USER DEF. KEY *****
320 | LBL1"INS. LOSS"
330 | LBL2"-30B B.W."
340 | LBL3"CENTER FREQ."
350 | LBL4"REJECTION"
360 | LBL5" TRIG"
370 | END

```

Program 2. Parameter Printing

```

100 | .....
110 | * FILTER TEST *
120 | * PRINT PARAMETER *
130 | * FOR HP 4195A * FEB.18.1988 *
140 | * YOKOGAWA-HEWLETT-PACKARD, LTD *
150 | .....
160 | ***** INITIALIZING *****
170 | SWHZ | SINGLE SWEEP
180 | CENTER=140 MHZ | CENTER FREQ. 140 MHZ
190 | SPAN=100 MHZ | SPAN 100 MHZ
200 | OSC1=-10 DBM | S1 OSC. LEVEL -10 DBM
210 | ATR1=0 | RI ATTEN. 0 DB
220 | ATT1=0 | T1 ATTEN. 0 DB
230 | RBW=10 KHZ | RES. BW 10 KHZ
240 | HADMZ | TALK ONLY
250 | DPB0 | TRACE B OFF
260 | SEND " "
270 | ***** FINDING PARAMETER *****
280 | SUTRG | MEAS. LOOP TOP <-----+
290 | MCF1;MKMX;R0=MKRA
300 | MCF4;MKACT1;MKMX;WIDTH1;DLCURS=-3;R1=WIDTH
310 | MCF4;MKACT1;MKMX;WIDTH1;DLCURS=-3;R2=(LCURS+LCURS)/2
320 | MCF2;MKACT1;MKMX;SMKR=CENTER-SPAN/3;R3=DMKRA
330 | ***** PRINTING DATA *****
340 | SEND "INSERTION LOSS [DB]"
350 | R07
360 | WAIT 500
370 | SEND " "
380 | SEND "-30B BAND WIDTH [HZ]"
390 | R17
400 | WAIT 500
410 | SEND " "
420 | SEND "CENTER FREQUENCY [HZ]"
430 | R27
440 | WAIT 500
450 | SEND " "
460 | SEND "REJECTION [DB]"
470 | R37
480 | WAIT 500
490 | SEND " "
500 | PRUSE
510 | GOTO 280 | MEAS. LOOP END ----> +
520 | END

```

Program 3. Limit Line Setting

```

100 | *****
110 | FILTER TEST LIMIT LINE SETTING *
120 | PROGRAM FOR HP 4195A
130 | FEB. 3, 1988 *
140 | YOKOGAWA-HEWLETT-PACKARD, LTD. *
150 | *****
160 | ***** SETTING INSTRUMENT STATE *****
170 | ***** SINGLE SNEEP *****
180 | ***** "LIMIT LINE SETTING" *****
190 | CENTER=140 MHZ | CENTER FREQUENCY
200 | SPAN=100 MHZ | SPAN
210 | OSC 1=-10 | TEST SIGNAL LEVEL (-50 THRU +15)
220 | ATR1=0 | REF ATT. (50,40,30,20,10 OR 0)
230 | ATT1=0 | TEST ATT. (50,40,30,20,10 OR 0)
240 | RBW=300K | RES BW (300K,100K,30K,10K,300,100,30,10 OR 3) requirements.
250 | NOP=41 | NUMBER OF POINT (2 THRU 401)
260 | ***** DEFINING NUMBER OF SEGMENTS *****
270 | RBW=6 | NUMBER OF SEGMENT POINTS (2 THRU 401 & LESS THAN NOP)
280 | R19=R9-1 | NUMBER OF LINE SEGMENTS
290 | ***** DEFINING SEGMENTS *****
300 | RAK(1)=START | UPPER LIMIT LINE FREQ.
310 | RAK(2)=110M
320 | RAK(3)=130M
330 | RAK(4)=150M
340 | RAK(5)=170M
350 | RAK(6)=STOP
360 |
370 | RBK(1)=START
380 | RBK(2)=120M
390 | RBK(3)=130M
400 | RBK(4)=150M
410 | RBK(5)=160M
420 | RBK(6)=STOP
430 |
440 | RC(1)=-60
450 | RC(2)=-50
460 | RC(3)=-15
470 | RC(4)=-15
480 | RC(5)=-60
490 | RC(6)=-60
500 |
510 | RD(1)=-100
520 | RD(2)=-100
530 | RD(3)=-40
540 | RD(4)=-40
550 | RD(5)=-100
560 | RD(6)=-100
570 | ***** INITIALIZING AND PAUSING *****
580 | DPA0:DPB0:SPC0:SPD0
590 | MTHA0:MTHB0
600 | ***** STORING INST. STATE TO REGISTERS *****
610 | R0=CENTER
620 | R1=SPAN
630 | R2=START
640 | R3=STOP
650 | R4=OSC1
660 | R5=ATR1
670 | R6=ATT1
680 | R7=RBW
690 | R8=NOP
700 |
710 |

```

These instrument settings should be modified according to measurements requirements.

The number of segment points can be modified.

The frequencies and power levels of each segment of limit lines should be modified for the measurement requirements.

```

720 | R18=R8-1
730 |
740 | R20=SPAN/(NOP-1)
750 | ***** CALCULATING LIMIT LINES *****
760 | FOR R30=1 TO R19 | UPPER LIMIT LINE CALCULATION
770 | R31=R30+1
780 | R51=(RA(R30)-RA(1))/RZ0+1
790 | R52=(RA(R31)-RA(1))/RZ0+1
800 | FOR R32=R51 TO R52
810 | C(R32)=RZ0*(R32-R51)*(RC(R31)-RC(R30))/(RA(R31)-RA(R30))+RC(R30)
820 | NEXT R32
830 | R51=(RB(R30)-RB(1))/RZ0+1
840 | R52=(RB(R31)-RB(1))/RZ0+1
850 | FOR R32=R51 TO R52
860 | D(R32)=RZ0*(R32-R51)*(RD(R31)-RD(R30))/(RB(R31)-RB(R30))+RD(R30)
870 | NEXT R32
880 | NEXT R30
890 | ***** MEASUREMENT *****
900 | SUTRG
910 | ***** SETTING DISPLAY CONDITIONS *****
920 | SPCNG
930 | SCL1:REF=0:DIV=10
940 | SCL2:REF=0:DIV=10
950 | ***** SETTING EDIT SOFTKEYS *****
960 | DF1"R51=(HKR-START)/(SPAN/(NOP-1))+1:A(R51)=A(R51)+1"
970 | DF2"R51=(MKR-START)/(SPAN/(NOP-1))+1:A(R51)=A(R51)-1"
980 | DF3"R51=(HKR-START)/(SPAN/(NOP-1))+1:B(R51)=B(R51)+1"
990 | DF4"R51=(MKR-START)/(SPAN/(NOP-1))+1:B(R51)=B(R51)-1"
1000 | LBL1"A UP"LBL2"A DOWN"LBL3"B UP"LBL4"B DOWN"LBL5""
1010 | DPA1:DPB1:SPC1
1020 | DMA=A:DMB=B
1030 | PRMA"UP"PRMB"LOW"PRNB"DB"PRNC"DB"PRND"DB"
1040 | MTHA1:MTHB1
1050 | ***** ENDING *****
1060 | DISP "IF DONE, PLEASE SAVE YOUR DATA."
1070 | BEEP
1080 | CRT""
1090 | END

```

Program 4. GO/NO-GO Testing

```

100 |*****
110 |* FILTER TEST (GO NOGO) PROGRAM *
120 |*
130 |*
140 |* YOKOGAWA-HEWLETT-PACKARD, LTD. *
150 |*****
160 |***** INITIALIZING AND PAUSING *****
170 |*****
180 |*****
190 |*****
200 |*****
210 |*****
220 |*****
230 |*****
240 |*****
250 |*****
260 |*****
270 |*****
280 |*****
290 |*****
300 |*****
310 |*****
320 |*****
330 |*****
340 |*****
350 |*****
360 |*****
370 |*****
380 |*****
390 |*****
400 |*****
410 |*****
420 |*****
430 |*****
440 |*****
450 |*****
460 |*****

```



For more information, call your local HP sales office listed in the telephone directory white pages. Ask for the Electronic Instrument Department, or write to Hewlett-Packard: U.S.A. - P.O. Box 10301, Palo Alto, CA 94303-0890. Europe - Hewlett-Packard S.A., P.O. Box 529, 1180 AM Amstelveen, The Netherlands. Canada - 6877 Goreway Drive, Mississauga, L4V 1M8, Ontario. Japan - Yokogawa-Hewlett-Packard Ltd., 3-29-21, Takaido-Higashi, Suginami-ku, Tokyo 168. Far East - Hewlett-Packard Asia Headquarters, 47/F China Resources Building, 26 Harbour Road, Wanchai Hong Kong. Australasia - Hewlett-Packard Australia Ltd., 31-41 Joseph Street, Blackburn, Victoria 3130 Australia. Latin America - Hewlett-Packard Latin America Headquarters, 3495 Deer Creek Rd., Palo Alto, CA 94304. For all other areas, please write to: Hewlett-Packard Intercontinental Headquarters, 3495 Deer Creek Rd., Palo Alto, CA 94304.

Printed in Japan

April, 1988

5950-2933